

DESIGN FEATURES

- Built-in ISO 5211 Direct Mounting Pad Easy Automation
- Anti-static Devices for Ball-Stem-Body
- Blow-out Proof Stem
- TA-Luft Design Approved
- NACE standard MR0175 & MR0103 (Optional)
- Casting Approved by TÜV AD 2000-Merkblatt W0
- Top Entry For DN125~DN200
- Positive Position Location At 90° Increments
- Multi-Port Configuration
- KV-L5J/L, KV-L5K/L, KV-L5M/L, KV-5N/L:L-Port
KV-L5J/T, KV-L5K/T, KV-L5M/T, KV-5N/T:T-Port
KV-L5J/X, KV-L5K/X, KV-L5M/X, KV-L5N/X:LL-Port
- Options: 1.Actuator 2.Limit Switch 3.Positioner



APPLICABLE STANDARDS

- Design Standard : DIN 3357/1, 2, EN12516-1
- Wall Thickness : ASME16.34
- Flanged End : EN 1092-1 PN10-40
- Inspection & Testing : EN12266-1



TORQUE VALUES

Close to Open Torque at Various Differential Pressure (ΔP), Standard Seats (TFM1600&PTFE)

unit : in·lb / N·m

Size/ ΔP		75 psig		150 psig		300 psig		600 psig	
		5 bar		10 bar		20 bar		40bar	
NPS	DN	N·m	In·lb	N·m	In·lb	N·m	In·lb	N·m	In·lb
1/2	15	9	80	9	80	10	88	10	88
3/4	20	14	124	14	124	15	133	15	133
1	25	18	159	18	159	19	168	22	195
1 1/4	32	25	221	26	230	27	239	33	292
1 1/2	40	35	310	38	283	42	372	46	407
2	50	45	398	50	336	56	496	65	575
2 1/2	65	70	619	79	699	86	761	100	885
3	80	110	973	122	1080	138	1221	160	1416
4	100	190	1681	209	1850	232	2053	265	2345
5	125	360	3186	390	3452	460	4071	580	5133
6	150	580	5133	640	5664	700	6195	860	7611
8	200	680	6018	800	7080	920	8142	1150	10117

- Remark :
- 1.Torques will increase about 30% if seat materials are Reinforced Fiber-Glass PTFE, Carbon-filled. PTFE or EK+PTFE or EK+PTFE or TFM4215.
 - 2.The torque figures at 5 bar pressure are maximum values to be tested after the valves are placed for 24 hours.
 - 3.For actuator sizing, a safety factor of minimum 30% is recommended.

CV VALUE / WEIGHT

DN	Weight (kg)			
	L-Port		T-Port	
	PN16	PN40	PN16	PN40
15	4.408		4.4	
20	5.85		5.85	
25	8.4		8.15	
32	11.35		10.8	
40	13.9		14.4	
50	19.186		19.01	
65	31.676	—	31.4	—
80	48.3	—	47.4	—
100	64.382	—	63.56	—

TECHNICAL INFORMATION

PRESSURE - TEMPERATURE DATA

The pressure-temperature data of ball valves is determined not only by valve shell materials but also by sealing materials used for ball seats, gland packings and flange gaskets.

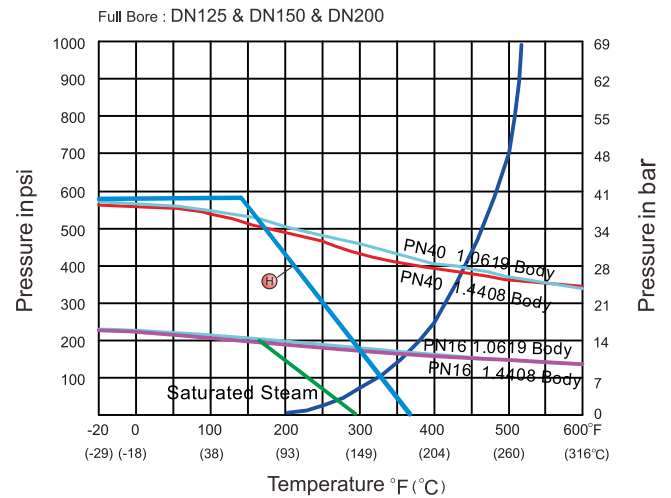
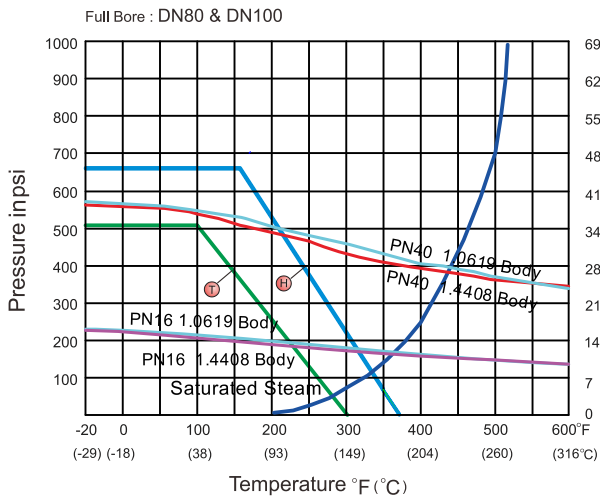
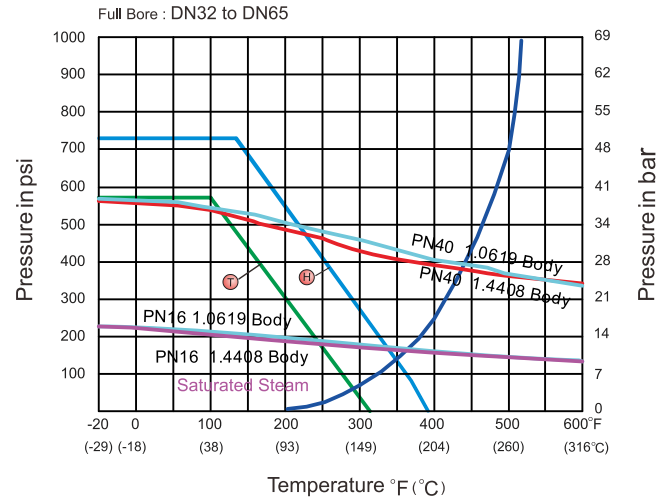
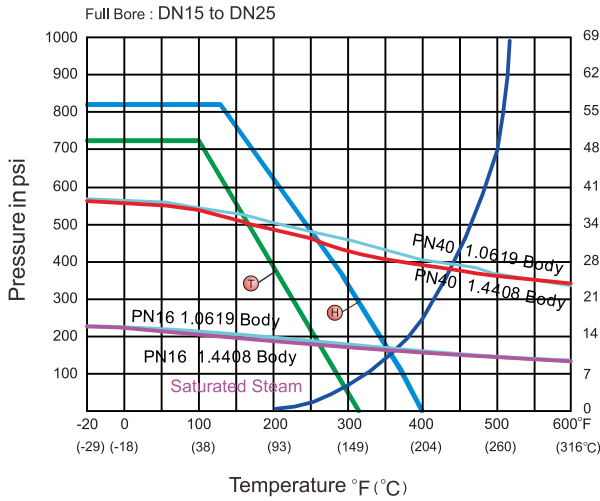

Seat Materials : Ⓧ PTFE Ⓜ TFM1600

Body Ratings: Shown above are for EN10213 Nr. 1.4408 and EN 10213 Nr. 1.0619 For ratings of other valve shell materials, please refer to the last edition of EN12516-1.

EN 1092-1 PN10-40
3 & 4 - Way Full Port Flanged Ends Ball Valve

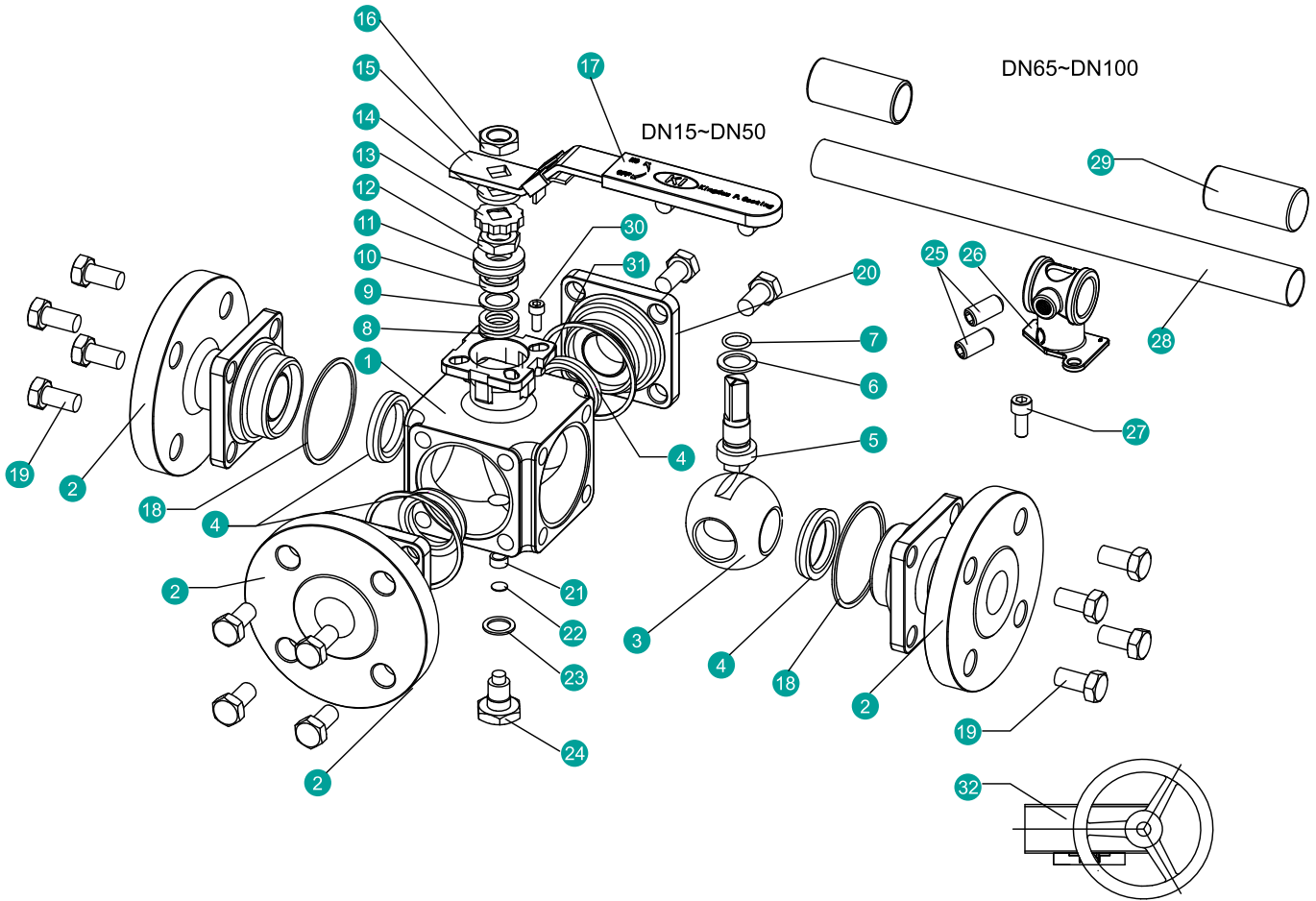

MATERIAL OF CONSTRUCTION

NO.	PART NAME	MATERIALS		
1	Body	1.4408	1.4308	1.0619
2	End Cap (1)	1.4408	1.4308	1.0619
3	Ball	1.4408	1.4308	
4	Ball Seat	TFM1600 / PTFE		
5	Stem (Anti-Static Device)	316	304	
6	Thrust Washer	PTFE		
7	O-Ring	FKM		
8	Stem Packing	PTFE / GRAPHITE		
9	Bushing	50%SS+50%PTFE / 304*		
10	Gland	316		
11	Belleville Washer	301		
12	Stem Nut	A194-8		
13	Stop-lock-Cap	304		
14	Handle Gland (DN15 ~ DN100)	304		
15	Handle+Lock Device (DN15~DN50)	304		
16	Handle Nut (DN15~DN50)	A194-8		
17	Handle Sleeve (DN15 ~ DN65)	PVC		
18	Body Gasket (1)	PTFE/GRAPHITE		
19	Bolt	A2-70		8.8
20	End Cap (2)	1.4408	1.4308	1.0619
21	Washer	50%SS+50%PTFE		
22	Bushing	50%SS+50%PTFE		
23	Body Gasket (2)	PTFE / GRAPHITE		
24	Bottom Cap	1.4408	1.4308	1.0619
25	Set Screwed (DN65 ~ DN100)	A2-70		
26	Handle Adapter (DN65 ~ DN100)	CF8		
27	Bolt (DN65 ~ DN100)	A2-70		
28	Handle (DN65 ~ DN100)	A53+ZnPlated		
29	Handle Sleeve (DN65 ~ DN100)	PVC		
30	Stop Bolt (DN15 ~ DN100)	A2-70		
31	Stop Nut (DN15 ~ DN100)	A2-70		
32	Worm Gear (DN125 ~ DN200)	Package		

EN 1092-1 PN10-40
3 & 4 - Way Full Port Flanged Ends Ball Valve

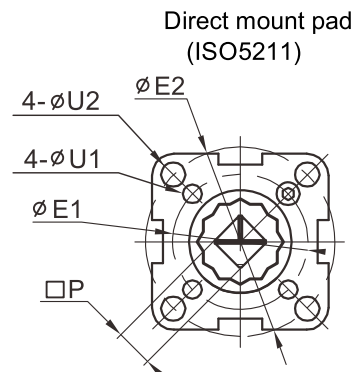
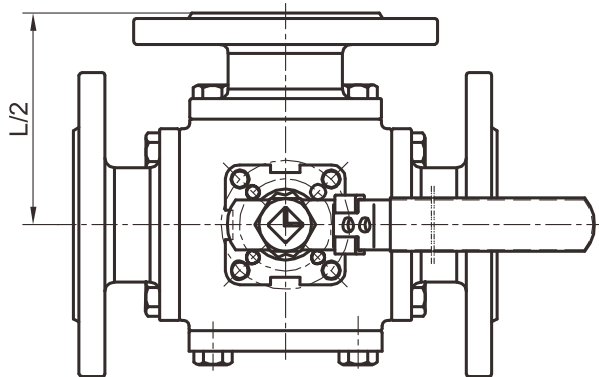
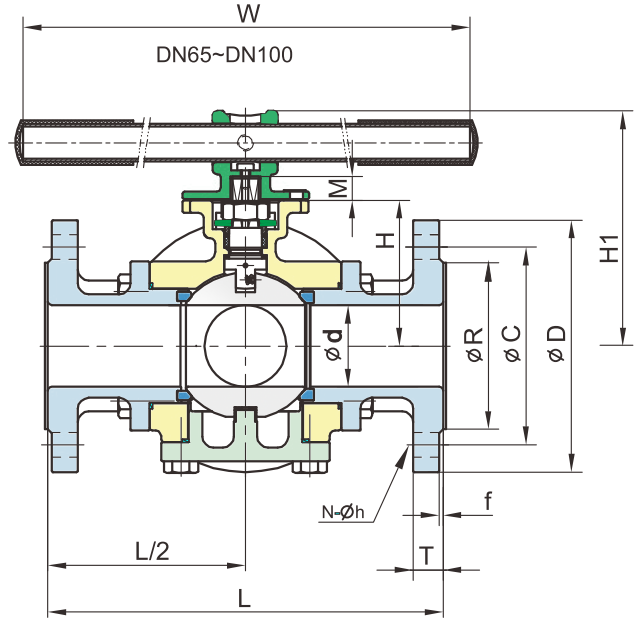
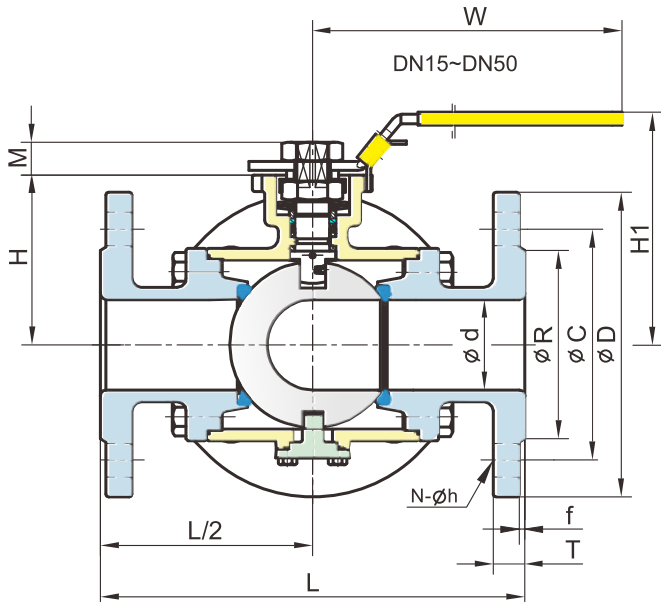

DIMENSION TABLE

EN PN10/16/25/40

Unit : mm

DN	PN	d	L	R	D	C	f	T	N	h	H	H1	W	P	M	E1	E2	U1	U2	ISO 5211
15	10	15	150	45	95	65	2	16	4	14	53	83	147	9	9	36	42	6	6	F03-F04
20		20	165	58	105	75	2	18	4	14	57	87	147	9	9	36	50	6	7	F03-F05
25	16	25	181	68	115	85	2	18	4	14	68	99	177	11	11	42	50	6	7	F04-F05
32	25	32	190	78	140	100	2	18	4	18	72	103	177	11	11	42	50	6	7	F04-F07
40	40	38	212	88	150	110	3	18	4	18	85	119	197	14	14	50	70	7	9	F05-F07
50		49	230	102	165	125	3	20	4	18	92	126	197	14	14	50	70	7	9	F05-F07
65	10/16	60	290	122	185	145	3	18	8	18	107	172	400	17	17	70	102	9	11	F07-F10
	22																			
80	10/16	75	310	138	200	160	3	20	8	18	119	185	400	17	17	70	102	9	11	F07-F10
	24																			
100	10/16	99	352	158	220	180	3	20	8	18	150	221	400	22	22	—	102	—	11	F10
	24																			

KV-L5J — **PN10**
KV-L5M — **PN25**

KV-L5K — **PN16**
KV-L5N — **PN40**

(DN125~DN200)

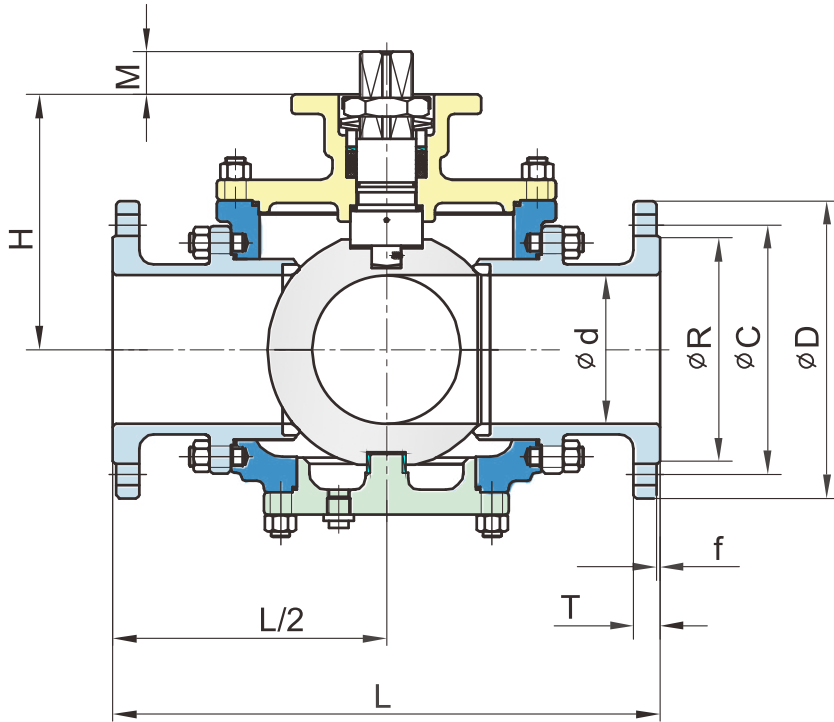

Gear Operation (Standard Type)
SIZE: DN125~DN200

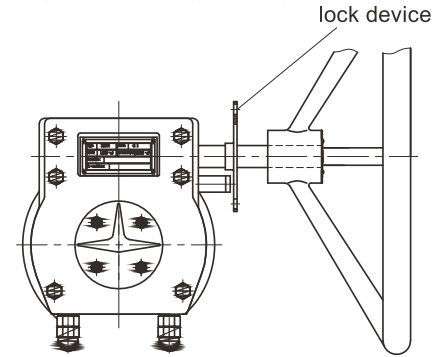

Automation (Optional)

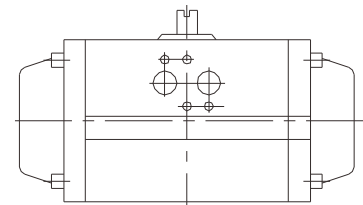

Direct mount pad
(ISO5211)

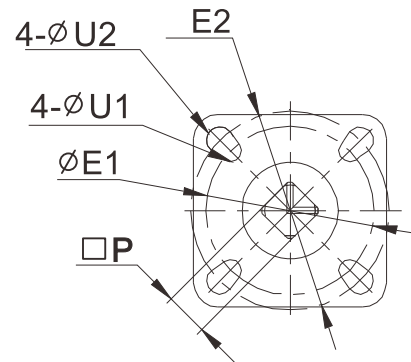
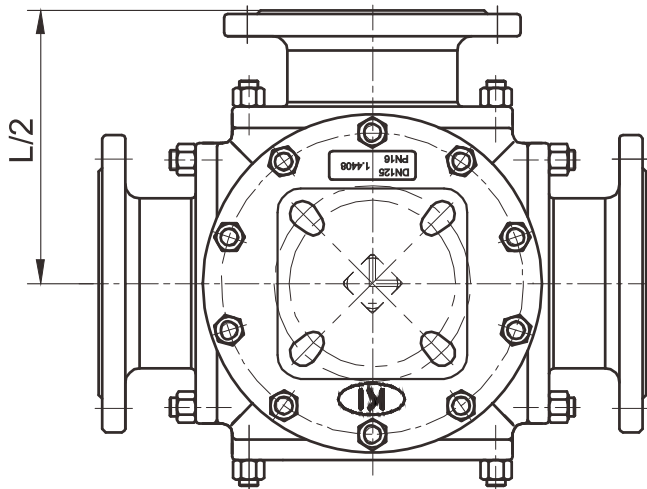

EN PN10/16/25/40 (F1 / F7, F4 / F5)

Unit : mm

DN	PN	d	L	R	D	C	f	T	N	h	H	P	M	E1	E2	U1	U2	ISO 5211
125	10/16	125	460	188	250	210	3	22	8	18	215	36	36	140	165	18	22	F14-F16
	25/40		480		270	220		26		26								
150	10/16	150	490	212	285	240	3	22	8	22	228.5	36	36	140	165	18	22	F14-F16
	25/40		520		300	250		28		26								
200	10	200	620	268	340	295	3	24	8	22	281.5	36	36	140	165	18	22	F14-F16
	16							26										
	25		12	278	360	310		30	26									
	40			285	375	320		34	30									

FLOW PATTERNS FOR 3 WAY VALVE

T-PORT 90° TURN

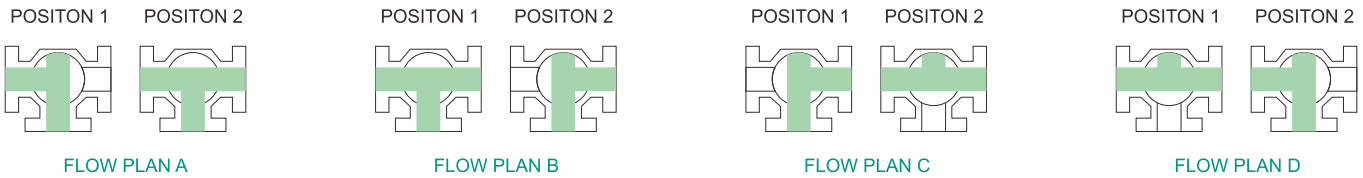

T-PORT 180° TURN

